







Wood and 5-Piece MDF Frame Only Doors

Most Conestoga wood and MDF door designs are available with a frame only option to match your solid panel door designs. Frame only doors are a perfect accent and can accommodate a wide array of decorative glass, wire mesh and other inserts.

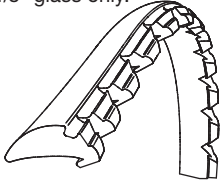
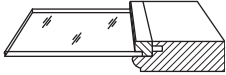
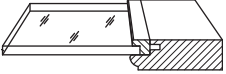
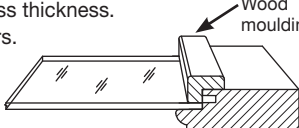
Frame Only and Mullion Framing Options		
 <p>Regular bead shown</p> <p>Frame only doors come standard with glass retainer moulding groove.</p>	 <p>Non-grooved framing is available. Simply specify "No rout for retainer moulding" in the special instructions portion of the order form.</p>	
Retainer Moulding Options (specify moulding number)		
<p>Clear (standard) for 1/8" glass only.</p> 	<p>#906 for 1/8" glass only.</p>  <p>#907 for 1/4" glass.</p> 	<p>#52 for varying glass thickness. Use on radius doors.</p>  <p>#83 (similar to #52) for Barcelona, Bristol, Cortland and TW-10916. Wood retainer mouldings should be predrilled to avoid splitting.</p> <p>Wood moulding</p>

Wood and 5-Piece MDF Mullion Doors

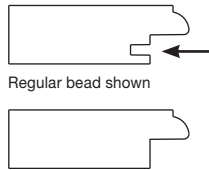
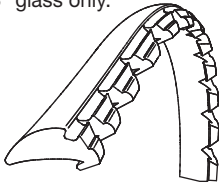
Conestoga offers a wide variety of mullion configurations and options. Mullions illustrated on the following pages are only a representation of the available patterns. Contact our Special Designs Department for additional mullion information. MDF mullion doors will be constructed with MDF framing and Paint Grade Hard Maple mullion strips.

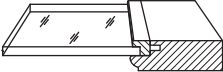
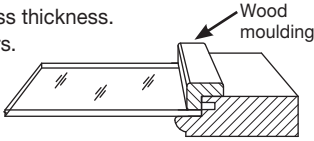
Wood and 5-Piece MDF Mullion Design Options		
Design		Design Notes
F-007, Regular and Ogee bead mullions F-1223, Square bead mullions		<ul style="list-style-type: none"> Fitted for one piece of glass per door.
Elite, F-877, Special (mullion bead differs from framing bead) Odd mullion configuration <i>Odd mullion configuration 1-Piece MDF doors will be priced by our Special Designs Department.</i>		<ul style="list-style-type: none"> Fitted for one piece of glass per door. Special mullions apply to all miter designs except CRP-10 Miter.
True Divided Lites F-007, Regular and Ogee bead mullions F-1223, Square bead mullions F-877, Elite/Special (mullion bead differs from framing bead) Odd mullion configuration		<ul style="list-style-type: none"> Fitted for individual pieces of glass per lite. These doors have 7/8" wide mullions unless otherwise specified. Glass retainer moulding not supplied.
Mullion Width Details		Frame Only and Mullion Framing Options
Framing Bead	Mullion Width	
Regular	5/8" wide for 3/4" thick doors 3/4" wide for 1" thick doors	 <ul style="list-style-type: none"> Mullion doors come standard with glass retainer moulding groove. Non-grooved framing is available. Simply specify "No rout for retainer moulding" in the special instructions portion of the order form.
Elite, F-877, F-1223, Square	5/8"	
F-007	15/16"	
Ogee	7/8"	
Retainer Moulding Options (specify moulding number)		
<p>Clear (standard) for 1/8" glass only.</p> 	<p>#906 for 1/8" glass only.</p>  <p>#907 for 1/4" glass.</p> 	<p>#52 for varying glass thickness. Use on radius doors.</p>  <p>#83 (similar to #52) for Barcelona, Bristol, Cortland and TW-10916. Wood retainer mouldings should be predrilled to avoid splitting.</p>

1-Piece MDF Mullion and Frame Only Doors

1-Piece MDF Mullion and Frame Only Pricing		
Design		
Radius Corner Series		
Square Corner Series		
Mullion Lite Options		
Mullion lite placement will be balanced. Indicate number of lites desired.		
Design		Design Notes
Standard Lites		<ul style="list-style-type: none"> Standard mullion lites have radius corners, are fitted for one piece of glass, and are used on RC series doors. Mullions available: 10RC, 10RC2, 10RC3, 10SQF1, 10SQF28.
Special Lites		<ul style="list-style-type: none"> Special mullion lites are fitted for one piece of glass, have square corners, and are used on applicable SQ Series doors. Mullions available: 10SQ3, 10SQ5, 30SQ3.
Clear plastic moulding is standard on MDF mullion doors. If using glass other than 1/8" thick, specify our #52 moulding retainer.		

Frame Only with Panel

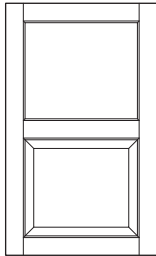

- Most 5-piece wood and MDF door designs are available with a frame only and panel.
- Only available as a 2 opening upright door. Specify frame only opening dimensions.
- All published wood species and select MDF designs are available.
- All 3/4" framing beads available. Regular, Ogee and Square also available in 1".
- For panel, all published panel raises and plywood panel designs are available (subject to design limitations).
- Clear plastic retainer moulding standard unless otherwise specified. Wood retainer moulding or no retainer moulding options available.
- True divided lite option available. Upcharge applies.
- Mullion with panel also available. Contact Special Designs.

Mullion Doors

6

Accent Doors & Panels

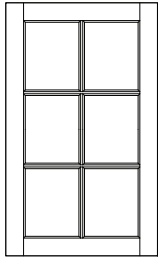

Standard Lite Mullion

- Specify 4-lite, 6-lite, 8-lite, 10-lite or 12-lite when ordering.
- All lites will be evenly spaced unless otherwise requested. Odd mullion configuration charges will apply if custom spacing is requested.
- Standard Lite Mullions will be configured two lites wide regardless of size unless otherwise requested.
- All 3/4" framing beads available. Regular, Ogee, Square and Elite also available in 1".
- Matching mullion profiles in F-007, F-1223, Regular, Ogee and Square. Elite and F-877 framing beads receive Regular bead mullion profile.
- Minimum door size – 7-7/8" x 7-7/8" with 2-5/16" wide framing.
- Clear plastic retainer moulding standard unless otherwise specified. Wood retainer moulding or no retainer moulding options available.
- True divided lite option available. Upcharge applies.

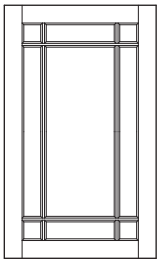

9-Lite Offset Mullion*

- 9-lite Offset Mullion features 2" x 2" corner lites standard.
- All 3/4" framing beads available. Regular, Ogee, Square and Elite also available in 1".
- Matching mullion profiles in F-007, F-1223, Regular, Ogee and Square. Elite and F-877 framing beads receive Regular bead mullion profile.
- Minimum door size – 11-7/8" x 11-7/8" with 2-5/16" wide framing.
- Clear plastic retainer moulding standard unless otherwise specified. Wood retainer moulding or no retainer moulding options available.
- Odd mullion configurations upcharge applies.
- True divided lite option available. Upcharge applies.

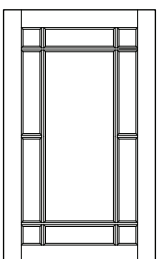

11-Lite Offset Mullion*

- 11-lite Offset Mullion features 2" x 2" corner lites standard.
- All 3/4" framing beads available. Regular, Ogee, Square and Elite also available in 1".
- Matching mullion profiles in F-007, F-1223, Regular, Ogee and Square. Elite and F-877 framing beads receive Regular bead mullion profile.
- Minimum door size – 11-7/8" x 14-5/8" with 2-5/16" wide framing.
- Clear plastic retainer moulding standard unless otherwise specified. Wood retainer moulding or no retainer moulding options available.
- Odd mullion configurations upcharge applies.
- True divided lite option available. Upcharge applies.

***Caution:** Long, continuous mullion strips are highly susceptible to bowing and warping. This condition is typically the result of moisture absorption and expansion of door framing which applies pressure against the mullion strips. Conestoga does not warranty mullions that bow due to exposure to high humidity conditions or environments. A clear adhesive applied between the back of the mullion strip and glass panel may help reduce the amount of noticeable mullion movement. Standard lite mullions are recommended for use in high moisture conditions.

Mullion Doors (continued)

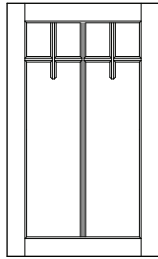

Odyssey Mullion*

- A 6 lite design with two mullion strips extending below horizontal mullion.
- A dimensioned sketch must accompany each Odyssey Mullion order.
- All 3/4" framing beads available. Regular, Ogee, Square and Elite also available in 1".
- Matching mullion profiles in F-007, F-1223, Regular, Ogee and Square. Elite and F-877 framing beads receive Regular bead mullion profile.
- Minimum door size – 14-7/8" x 11-3/8" with 2-5/16" wide framing.
- Clear plastic retainer moulding standard unless otherwise specified. Wood retainer moulding or no retainer moulding options available.
- Odd mullion configurations upcharge applies.
- True divided lite option available. Upcharge applies.

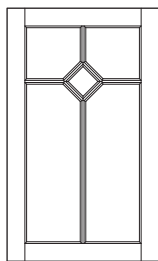

Diamond Mullion* / Double Diamond Mullion*

- Diamond Mullion features a 4" x 4" diamond lite centered in the width of the door opening and 4-1/2" from the top rail. The Double Diamond Mullion features two 4" x 4" diamond lites centered in the width of the door opening and 4-1/2" from top and bottom rails.
- All 3/4" framing beads available. Regular, Ogee, Square and Elite also available in 1".
- Matching mullion profiles in F-007, F-1223, Regular, Ogee and Square. Elite and F-877 framing beads receive Regular bead mullion profile.
- Diamond Mullion minimum door size – 12-5/8" x 18-5/8" with 2-5/16" wide framing. Double Diamond minimum door size – 12-5/8" x 25-1/4" with 2-5/16" wide framing.
- Clear plastic retainer moulding standard unless otherwise specified. Wood retainer moulding or no retainer moulding options available.
- Diamond Mullion receives a 5 lite Design Charge. Double Diamond Mullion receives an 8 lite Design Charge.
- Odd mullion configurations upcharge applies.

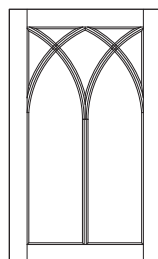
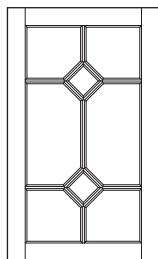

Arched Lite Mullion*

- Arched Lite Mullions feature 7 radius lites.
- All 3/4" framing beads available except F-877, F-1223 and Elite. Regular, Ogee and Square also available in 1". Ogee and F-007 framing bead may burnish when coped.
- Matching mullion profiles in F-007, Regular, Ogee and Square.
- Minimum door size – 11-5/8" x 9-5/8" with 2-5/16" wide framing.
- Clear plastic retainer moulding standard unless otherwise specified. Wood retainer moulding or no retainer moulding options available.
- Arched Lite Mullions will be quoted through Special Designs.
- Configuration not available in all sizes. A drawing will be sent to customer for approval prior to manufacturing process beginning.

***Caution:** Long, continuous mullion strips are highly susceptible to bowing and warping. This condition is typically the result of moisture absorption and expansion of door framing which applies pressure against the mullion strips. Conestoga does not warranty mullions that bow due to exposure to high humidity conditions or environments. A clear adhesive applied between the back of the mullion strip and glass panel may help reduce the amount of noticeable mullion movement. Standard lite mullions are recommended for use in high moisture conditions.

Mullion Doors (continued)

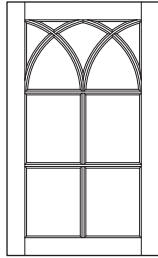

Arch Lite with Horizontal Lite Mullion

- Features 11 radius lites – rectangular lites will vary depending on height of door.
- 3/4" F-007, F-1223, Regular, Ogee and Square framing beads available. Regular, Ogee and Square also available in 1". Ogee and F-007 framing beads may burnish when coped.
- Matching mullion profiles in F-007, F-1223, Regular, Ogee and Square.
- Minimum door size – 11-5/8" x 9-5/8" with 2-5/16" wide framing.
- Clear plastic retainer moulding standard unless otherwise specified. Wood retainer moulding or no retainer moulding options available.
- Must be quoted through Special Designs.
- Configuration not available in all sizes. A drawing will be sent to customer for approval prior to manufacturing process beginning.

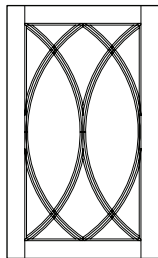

Continuous Double Arched Lite Mullion*

- Continuous Double Arched Lite Mullions feature 12 radius lites.
- All 3/4" framing beads available except F-877 and Elite. Regular, Ogee and Square also available in 1". Ogee and F-007 framing bead may burnish when coped.
- Matching mullion profiles in F-007, F-1223, Regular, Ogee and Square.
- Minimum door size – 11-5/8" x 14-15/16" with 2-5/16" wide framing.
- Clear plastic retainer moulding standard unless otherwise specified. Wood retainer moulding or no retainer moulding options available.
- Continuous Double Arched Lite Mullions quoted through Special Designs.
- Configuration not available in all sizes. A drawing will be sent to customer for approval prior to manufacturing.

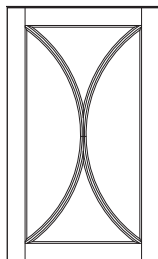

Double Bow Mullion

- Features 4 radius lites. Two symmetrical arches intersect in center of door opening.
- All 3/4" framing beads available. Regular, Ogee, Square and Elite also available in 1".
- Matching mullion profiles in F-007, F-1223, Regular, Ogee and Square. Elite and F-877 framing beads receive Regular bead mullion profile.
- Minimum door size – 11-5/8" x 11-5/8" with 2-5/16" wide framing.
- Clear plastic retainer moulding standard unless otherwise specified. Wood retainer moulding or no retainer moulding options available.
- Must be quoted through Special Designs.
- Configuration not available with all sizes. A drawing will be sent to customer for approval prior to manufacturing process beginning.

***Caution:** Long, continuous mullion strips are highly susceptible to bowing and warping. This condition is typically the result of moisture absorption and expansion of door framing which applies pressure against the mullion strips. Conestoga does not warranty mullions that bow due to exposure to high humidity conditions or environments. A clear adhesive applied between the back of the mullion strip and glass panel may help reduce the amount of noticeable mullion movement. Standard lite mullions are recommended for use in high moisture conditions.

Mullion Doors (continued)

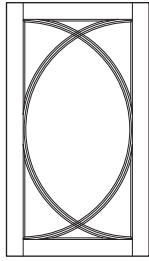

Vesica Mullion

- Features 7 radius lites.
- 3/4" F-007, F-1223, Regular, Ogee and Square framing beads available. Regular, Ogee and Square also available in 1".
- Matching mullion profiles in F-007, F-1223, Regular, Ogee and Square.
- Minimum door size – 8-5/8" x 15-15/16" with 2-5/16" wide framing.
- Clear plastic retainer moulding standard unless otherwise specified. Wood retainer moulding or no retainer moulding options available.
- Must be quoted through Special Designs.
- Configuration not available with all sizes. A drawing will be sent to customer for approval prior to manufacturing process beginning.

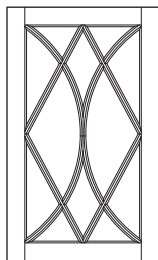

Double Bow Diamond Mullion

- Features double arch mullions and centered diamond with total of 12 lites.
- All 3/4" framing beads available except Elite. Regular, Ogee and Square also available in 1".
- Matching mullion profiles in F-007, F-1223, Regular, Ogee and Square. F-877 framing bead receives Regular bead mullion profile.
- Minimum door size – 11-5/8" x 14-15/16" with 2-5/16" wide framing.
- Clear plastic retainer moulding standard unless otherwise specified. Wood retainer moulding or no retainer moulding options available.
- Must be quoted through Special Designs.
- Configuration not available with all sizes. A drawing will be sent to customer for approval prior to manufacturing process beginning.

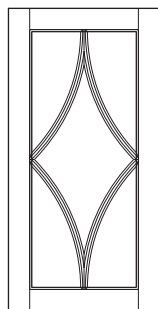

Single / Double Diamond Swag Mullion

- Features concave-shaped diamond(s) with 5 lites for Single Mullion and 8 lites for Double Mullion.
- All 3/4" framing beads available except F-877 and Elite. Regular, Ogee and Square also available in 1". Ogee and F-007 framing bead may burnish when coped.
- Matching mullion profiles in F-007, F-1223, Regular, Ogee and Square.
- Minimum door size –
Single – 11-5/8" x 11-5/8" with 2-5/16" wide framing.
Double – 11-5/8" x 23"

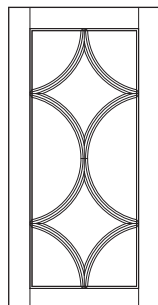

- Clear plastic retainer moulding standard unless otherwise specified. Wood retainer moulding or no retainer moulding options available.
- Must be quoted through Special Designs.
- Configuration not available with all sizes. A drawing will be sent to customer for approval prior to manufacturing process beginning.

***Caution:** Long, continuous mullion strips are highly susceptible to bowing and warping. This condition is typically the result of moisture absorption and expansion of door framing which applies pressure against the mullion strips. Conestoga does not warranty mullions that bow due to exposure to high humidity conditions or environments. A clear adhesive applied between the back of the mullion strip and glass panel may help reduce the amount of noticeable mullion movement. Standard lite mullions are recommended for use in high moisture conditions.

Mullion Doors (continued)

6

Accent Doors & Panels

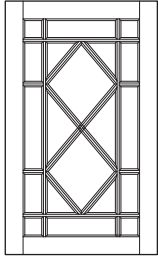

20 Lite Double Diamond Mullion*

- Features 20 lites with 2 diamond lites centered in door opening.
- All 3/4" framing beads available. Regular, Ogee, Square and Elite also available in 1".
- Matching mullion profiles in F-007, F-1223, Regular, Ogee and Square. Elite and F-877 framing beads receive Regular bead mullion profile.
- Minimum door size – 12-5/8" x 18-5/8" with 2-5/16" wide framing.
- Clear plastic retainer moulding standard unless otherwise specified. Wood retainer moulding or no retainer moulding options available.
- Must be quoted through Special Designs.
- Configuration not available with all sizes. A drawing will be sent to customer for approval prior to manufacturing process beginning.

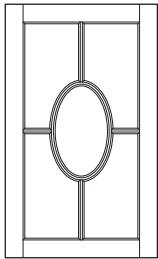

Elliptical Mullion*

- Features an elliptical shape centered in the middle of the door opening.
- Minimum opening of the elliptical shape is 2-1/2" x 5". Must specify size of the centered elliptical shape.
- All 3/4" framing beads available. Regular, Ogee, Square and Elite also available in 1".
- Matching mullion profiles in F-007, F-1223, Regular, Ogee and Square. Elite and F-877 framing beads receive Regular bead mullion profile.
- Minimum door size – 12-5/8" x 13-5/8" with 2-5/16" wide framing.
- Clear plastic retainer moulding standard unless otherwise specified. Wood retainer moulding or no retainer moulding options available.
- Must be quoted through Special Designs.
- A drawing will be sent to customer for approval prior to manufacturing process beginning.

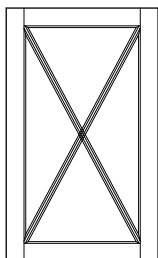

X-Lite Mullion*

- Features diagonal crisscrossed mullion pattern.
- All 3/4" framing beads available. Regular, Ogee, Square and Elite beads also available in 1".
- Matching mullion profiles in F-007, F-1223, Regular, Ogee and Square. Elite and F-877 framing beads receive Regular bead mullion profile.
- Minimum door size – 8-5/8" x 8-5/8" with 2-5/16" wide framing.
- Clear plastic retainer moulding standard unless otherwise specified. Wood retainer moulding or no retainer moulding options available.
- X-Lite Mullion receives a 4 lite Design Charge.
- Odd mullion configurations upcharge applies.

***Caution:** Long, continuous mullion strips are highly susceptible to bowing and warping. This condition is typically the result of moisture absorption and expansion of door framing which applies pressure against the mullion strips. Conestoga does not warranty mullions that bow due to exposure to high humidity conditions or environments. A clear adhesive applied between the back of the mullion strip and glass panel may help reduce the amount of noticeable mullion movement. Standard lite mullions are recommended for use in high moisture conditions.

Mullion Doors (continued)

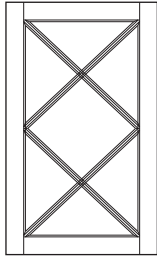

Double X Mullion / Double X Horizontal Lite Mullion

- Features two diagonal crisscrossed mullion patterns.
- Available with or without one centered horizontal mullion.
- All 3/4" framing beads available. Regular, Ogee, Square and Elite beads also available in 1".
- Matching mullion profiles in F-007, F-1223, Regular, Ogee and Square. Elite and F-877 framing beads receive Regular bead mullion profile.
- Minimum door size – 8-5/8" x 13-1/8" with 2-5/16" wide framing.
- Clear plastic retainer moulding standard unless otherwise specified. Wood retainer moulding or no retainer moulding options available.
- Double X Mullion receives a 7 lite Design Charge; Double X Horizontal Lite Mullion receives an 8 lite Design Charge.
- Double X and Double X Horizontal Lite Mullion openings are equal.
- Odd mullion configurations upcharge applies.

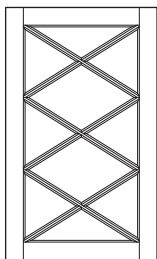
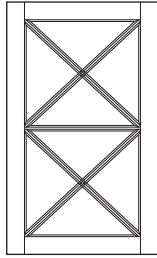

Triple X Mullion / Triple X Horizontal Lite Mullion

- Features three diagonal crisscrossed mullion patterns.
- Available with or without two centered horizontal mullions.
- All 3/4" framing beads available. Regular, Ogee, Square and Elite beads also available in 1".
- Matching mullion profiles in F-007, F-1223, Regular, Ogee and Square. Elite and F-877 framing beads receive Regular bead mullion profile.
- Minimum door size – 8-5/8" x 17-3/4" with 2-5/16" wide framing.
- Clear plastic retainer moulding standard unless otherwise specified. Wood retainer moulding or no retainer moulding options available.
- Triple X Mullion receives a 10 lite Design Charge; Triple X Horizontal Lite Mullion receives a 12 lite Design Charge.
- Triple X and Triple X Horizontal Lite Mullion openings are equal.
- Odd mullion configurations upcharge applies.

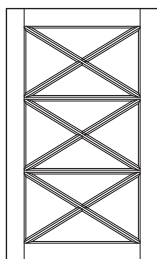

***Caution:** Long, continuous mullion strips are highly susceptible to bowing and warping. This condition is typically the result of moisture absorption and expansion of door framing which applies pressure against the mullion strips. Conestoga does not warranty mullions that bow due to exposure to high humidity conditions or environments. A clear adhesive applied between the back of the mullion strip and glass panel may help reduce the amount of noticeable mullion movement. Standard lite mullions are recommended for use in high moisture conditions.

Mullion Doors (continued)

6

Accent Doors & Panels

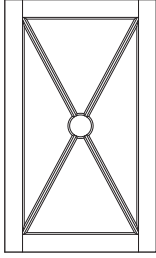

X-Lite w/Solid Hub

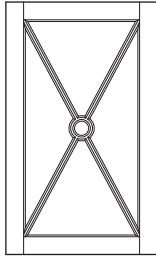

X-Lite w/Open Hub

X-Lite with Solid Hub Mullion* / X-Lite with Open Hub Mullion*

- Features diagonal crisscrossed mullion pattern with hub centered in the door opening. Hub can be open or solid.
- Open hub diameter is dependent on framing bead profile. Open hub with F-1223, Regular, Square and Elite beads will receive 3" diameter hub. Ogee bead will receive a 3-1/4" diameter hub. F-007 bead will receive a 3-7/8" diameter hub.
- Solid hubs for F-1223, Regular, Square and Elite bead mullions receive a 2" diameter hub. F007 and Ogee beads will receive a 3" diameter hub.
- All 3/4" framing beads available. Regular, Ogee, Square and Elite beads also available in 1".
- Matching mullion profiles in F-007, F-1223, Regular, Ogee and Square. Elite and F-877 beads receive Regular bead mullion profile.
- Minimum door size – 9-5/8" x 9-5/8" with 2-5/16" wide framing.
- Clear plastic retainer moulding standard unless otherwise specified. Wood retainer moulding or no retainer moulding options available.
- X-Lite with Open Hub Mullion receives a 5 lite Design Charge; X-Lite with Solid Hub Mullion receives a 4 lite Design Charge.
- Odd mullion configurations upcharge applies.

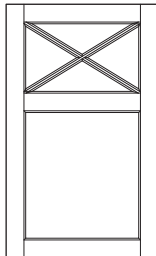

X-Lite Panel Mullion

- Features two-panel door with diagonal crisscrossed mullion pattern in top opening and a panel or frame only in the bottom opening.
- Customer must specify top opening size.
- All 3/4" framing beads available. Regular, Ogee, Square and Elite beads also available in 1".
- Matching mullion profiles in F-007, F-1223, Regular, Ogee and Square. Elite and F-877 beads receive Regular bead mullion profile.
- Minimum door size – 8-5/8" x 15-1/8" with 2-5/16" wide framing.
- Clear plastic retainer moulding standard unless otherwise specified. Wood retainer moulding or no retainer moulding options available.
- X-Lite with Panel Mullion receives a 4 lite Design Charge.
- Odd mullion configurations upcharge applies.
- For X-Lite with Panel Mullion pricing add Design Charge, then add individual lite charges and odd configuration upcharge.

***Caution:** Long, continuous mullion strips are highly susceptible to bowing and warping. This condition is typically the result of moisture absorption and expansion of door framing which applies pressure against the mullion strips. Conestoga does not warranty mullions that bow due to exposure to high humidity conditions or environments. A clear adhesive applied between the back of the mullion strip and glass panel may help reduce the amount of noticeable mullion movement. Standard lite mullions are recommended for use in high moisture conditions.

Mullion Doors (continued)

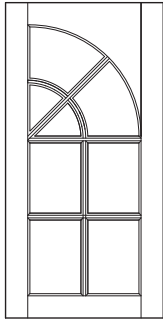

QC1000

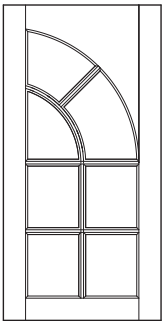

QC2000

QC1000 / QC2000 Mullions

- Quarter Circle mullion doors are typically ordered in sets. When left and right doors are paired on a cabinet, display case or piece of furniture, they create a highly attractive design element.
- 3/4" F-007, F-1223, Regular, Ogee and Square framing beads available.
- Matching mullion profiles available in F-007, F-1223, Regular, Ogee and Square.
- Minimum door width is 10" x 17" with 2-5/16" wide framing on face and 1-13/16" framing on back. Door height must always exceed the door width by at least 2-1/2".
- Specify the number of lites desired when ordering. The visual appeal of the QC mullion doors is greatly impacted by the number of lites.
 - ◆ For the QC1000 mullion design, consult the chart on page 6.12 to see the recommended number of lites per door size.
 - ◆ For the QC2000 mullion design, consult the chart on page 6.13 to see the recommended number of lites per door size.
- Clear plastic retainer moulding standard unless otherwise specified. Wood retainer moulding and no retainer moulding options available.
- True divided lite option available. Upcharges apply.

QC3000 Mullion

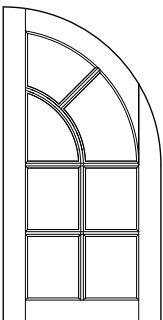

QC3000

- Quarter Circle mullion doors are typically ordered in sets. When left and right doors are paired on a cabinet, display case or piece of furniture, they create a highly attractive design element.
- 3/4" F-007, F-1223, Regular, Ogee and Square framing beads available.
- Matching mullion profiles available in F-007, F-1223, Regular, Ogee and Square.
- Minimum door width is 10" x 17" with 2-5/16" wide framing on face and 1-13/16" framing on back. Door height must exceed the door width by at least 2-1/2".
- Specify the number of lites desired when ordering. The visual appeal of the QC mullion doors is greatly impacted by the number of lites.
 - ◆ For the QC3000 mullion design, consult the chart on page 6.13 to see the recommended number of lites per door size.
- Clear plastic retainer moulding standard unless otherwise specified. #52 wood retainer moulding and no retainer moulding options available.

Quarter Circle 1000 Radius Mullion Recommendations

Use this chart to determine the ideal number of mullion lites for a given Quarter Circle 1000 door size or to determine availability for a given door size.

6

Accent Doors & Panels

Door/Mullion Lite Availability and Recommendations																	
Height	10	11	12	13	14	15	16	17	18	19	20	21	22	23	24	25	26
12																	
13																	
14																	
15																	
16																	
17																	
18																	
19																	
20																	
21																	
22																	
23																	
24																	
25																	
26																	
27																	
28																	
29																	
30																	
31																	
32																	
33																	
34																	
35																	
36																	
37																	
38																	
39																	
40																	
41																	
42																	
43																	
44																	
45																	
46																	
47																	
48																	

NOT AVAILABLE

NOT RECOMMENDED

6

8

10

14

12

Sizes exceeding 48" in height must specify number of lites.



Quarter Circle 2000 and 3000 Radius Mullion Recommendations

Use this chart to determine the ideal number of mullion lites for a given Quarter Circle 2000 and 3000 door size or to determine availability for a given door size.

Door/Mullion Lite Availability and Recommendations																	
Height	10	11	12	13	14	15	16	17	18	19	20	21	22	23	24	25	26
12																	
13																	
14																	
15																	
16																	
17																	
18																	
19																	
20																	
21																	
22																	
23																	
24																	
25																	
26																	
27																	
28																	
29																	
30																	
31																	
32																	
33																	
34																	
35																	
36																	
37																	
38																	
39																	
40																	
41																	
42																	
43																	
44																	
45																	
46																	
47																	
48																	

NOT AVAILABLE

NOT RECOMMENDED

5

7

9

11

13

Sizes exceeding 48" in height must specify number of lites.

CRP-10 and TW-10 Pilaster Doors

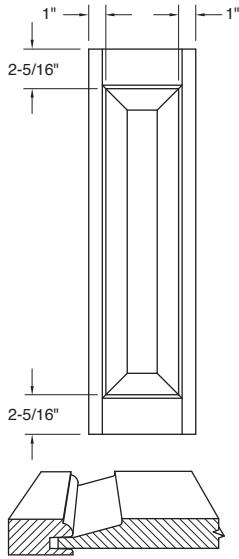

CRP-10 Pilaster Door

5-3/4" x 7-3/8"
 Slant raise shown

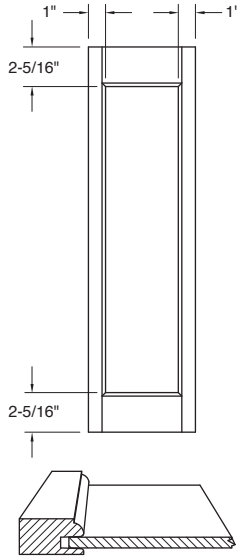

TW-10 Pilaster Door

3-3/4" x 5"
 1/4" Veneered panel

Offering And Availability

All Conestoga products are available in a wide variety of specifications to satisfy your custom needs. The information below indicates any exceptions or limitations pertaining to the designs shown above. For a detailed listing of a particular product specification, refer to the page indicated.

Species	
Material Pricing Guide	CRP-10 – all 3/4" species available. TW-10 – all 3/4" species available except Rustic Knotty and Soft Maple.
Edge Profiles	
pg 7.1	Design specific, no options available (Machine edge only).
Framing Beads	
pg 7.2	All 3/4" profiles available.
Panel Raises	
pg 7.2	CRP-10 – all 3/4" profiles available. TW-10 – 1/4" panel only.
Options	
pgs 7.3-7.15	Available with pegs, cut-downs, distressing, cross grain sanding, antiquing, non-standard width framing, putty pin holes, weathered grain, back-routed hand pull and G-012, G-015 and G-056 panel grooving.

All plywood panel designs use a 1/4" veneered, composite core panel. All panels except White Birch use plain sliced face or half round face and rotary back veneer. White Birch uses a rotary face and back. Vertical grain direction standard unless otherwise noted; horizontal grain available upon request. Minimums listed are based on panel raise shown and will vary by raise; see Offering and Availability for additional options. Framing width listed is determined by measuring across the back of the framing unless otherwise noted.

CRP-10 and TW-10 Pilaster Posts

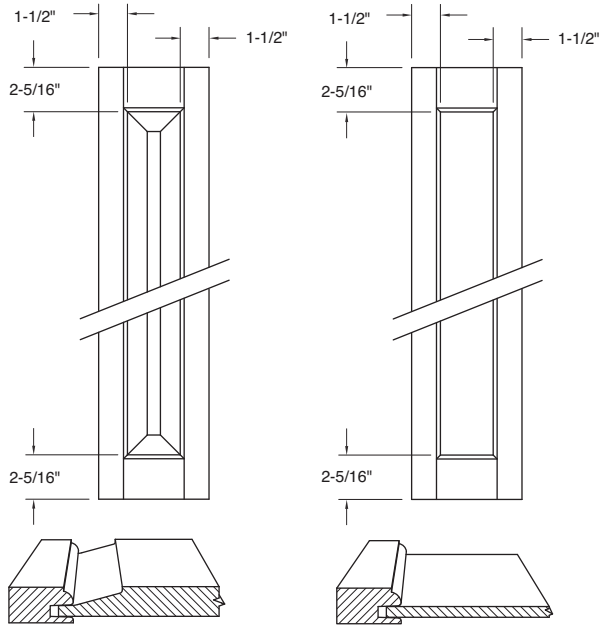

CRP-10 Pilaster Posts

5-3/4" x 7-3/8"
Slant raise shown

TW-10 Pilaster Posts

4-3/4" x 5"
1/4" Veneer panel

Minimums listed are based on panel raise shown and will vary by raise.

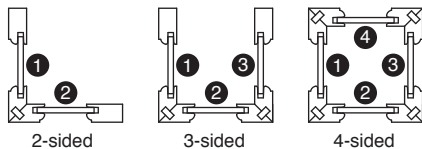

(TW-10 shown)

- Standard framing widths: 1-1/2" stiles, 2-5/16" rails and 2-1/2" middle rails.
- Posts cannot exceed 12" x 96".
- Standard lead-time 10 days; add 5-6 days for finishing.
- 2-sided and 3-sided pilaster posts are available assembled only.
- Loose side option available only with four sided Pilaster Post; no additional charge. Post will be constructed as an assembled three sided post with the fourth side held in place with loose splines which can be easily removed, then reinserted at the jobsite.
- During the finishing process it is possible that some finish materials may get on exposed edges. This finishing material should be removed before glue is applied to allow for a proper glue bond.
- CRP-10 and TW-10 Pilaster Posts have the option to receive a slab on any side. When ordering refer to drawing (left) and specify side(s) receiving slab.
- 4-sided posts with slab will not be warranted for open joints or a crack in slab due to expansion and contraction of the post itself.

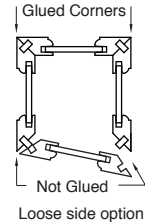

Pilaster Post Pricing			
	CRP-10	TW-10	Assembly Charge
2 sided			
3 sided			
4 sided			

*Assembly pricing per post; posts over 48" high will receive an additional assembly charge per post.

Offering And Availability	
Species	
Material Pricing Guide	CRP-10 – all 3/4" species available. TW-10 – all 3/4" species available except Rustic Knotty and Soft Maple.
Edge Profiles	
pg 7.1	Design specific, no options available.
Framing Beads	
pgs 7.2	All 3/4" profiles available.
Panel Raises	
pgs 7.2	CRP-10 – all 3/4" profiles available. TW-10 – 1/4" panel only.
Options	
pg 7.3-7.15	Available with pegs, distressing, cross grain sanding, antiquing, non-standard width framing and panel grooves.

Wood Accent Doors

6

Accent Doors & Panels



Crossback

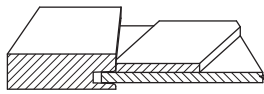

8" x 8"
 2-5/16" framing
 1/4" Veneer panel



CRP-10103

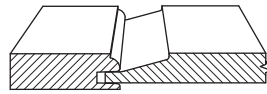

12-7/8" x 12-7/8"
 2-5/16" framing
 Top panel standard with horizontal grain. Specify height of top opening.
 Slant raise shown



CWS-10302

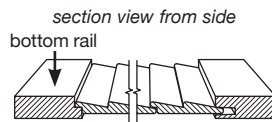

7-1/2" x 7-1/2"
 Stiles - 2-5/16" framing
 Rail width varies from 2" to 2-13/16" depending on height of door.



CWS-10446

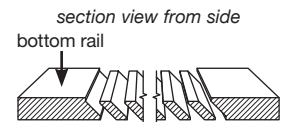

7-1/2" x 7-1/2"
 Stiles - 2-5/16" framing
 Top rail - 2-5/16" framing on face
 Bottom rail - framing varies from 2-1/8" to 2-15/16" on face.



Half Circle

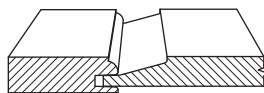

8-1/2" x 13"
 Max. width - 26"
 2-5/16" framing
 Slant raise shown



HL/HR-20

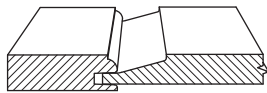

8-1/4" x 9"
 2-5/16" framing
 HL-20 (left side door shown)
 Slant raise shown



HL/HR-90

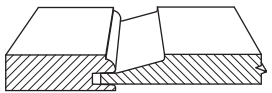

10" x 11-1/8"
 2-5/16" framing
 HR-90 (right side door shown)
 Slant raise shown



Presidential Cathedral



12" x 11-1/8"
 2-3/4" framing
 Presidential raise shown

Due to construction complexity, all multi-panel Presidential Cathedral doors include an additional charge per middle rail and middle stile plus the per panel Design Charge. Minimums listed are based on panel raise shown and will vary by raise; see Offering and Availability for additional options. Framing width listed is determined by measuring across the back of the framing unless otherwise noted. Narrow point of arched and cathedral rails are equal to the width of the stiles.



Offering And Availability

All Conestoga products are available in a wide variety of specifications to satisfy your custom needs. The information below indicates any exceptions or limitations pertaining to the designs on the previous page. For a detailed listing of a particular product specification, refer to the page indicated.

Species	
Material Pricing Guide	Crossback – all 3/4" species available except Rustic Knotty and Soft Maple. CRP-10103, HL/HR-20, HL/HR-90 and Half Circle – all 3/4" species available, all 1" species available. CWS-10302 and CWS-10446 – all 3/4" species available except Quarter Sawn and Rustic Knotty. Presidential Cathedral – all 3/4" species available.
Edge Profiles	
pg 7.1	CRP-10103, HL/HR-20, HL/HR-90 and Half Circle – all 3/4" and 1" profiles available. Crossback, CWS-10302, CWS-10446 and Presidential Cathedral – all 3/4" profiles available.
Framing Beads	
pg 7.2	CRP-10103, HL/HR-20, HL/HR-90 and Half Circle – all 3/4" and 1" profiles available. Crossback, CWS-10302, CWS-10446 and Presidential Cathedral – design specific, no options available.
Panel Raises	
pg 7.2	CRP-10103, HL/HR-20 and Half Circle – all 3/4" and 1" profiles available. Crossback, CWS-10302 and CWS-10446 – design specific, no options available. HL/HR-90 and Presidential Cathedral – all available except Louis XIII and P-602.
Options	
pgs 7.3-7.15	CRP-10103, HL/HR-20, HL/HR-90 and Half Circle – all options available. Crossback, CWS-10302, CWS-10446 and Presidential Cathedral – all options available except panel grooves. Note: CWS-10302 available with non-glazed Colourtones and Prism Paints, glazed and non-glazed wiping stains and Truetones. CWS-10446 available in glazed and non-glazed wiping stains only.
Mullions	
pgs 6.1-6.11	Crossback – Square bead X-lite recommended. CRP-10103, Half Circle, HL/HR-20, HL/HR-90 and Presidential Cathedral – all available, Presidential Cathedral incurs special lite charge. CWS-10302 and CWS-10446 – order as CRP-10 mullion with Square bead and Square bead mullions. Note: Half Circle mullion placement varies according to door width. Specify configuration to ensure that mullions align when using Half Circle doors with varying widths, or with other mullion designs.
Appliance Panels	
pg 6.22	Apply over plywood.
Matching/Complementary Drawer Fronts	
pgs 4.14-4.15, 4.58-4.59	Crossback – slab drawer front recommended. CRP-10103, CWS-10302, CWS-10446, HL/HR-20, HL/HR-90 and Half Circle – CRP-10 drawer front recommended. Presidential Cathedral – Presidential drawer front recommended.

Wood Accent Doors (continued)



X Side Panel

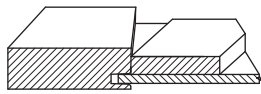

9-1/2" x 12-1/2"
3" stiles and top rail
6" bottom rail
1/4" Veneer panel



X Side Open

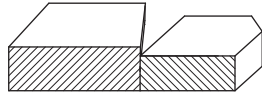

9-1/2" x 12-1/2"
3" stiles and top rail
6" bottom rail
Open frame

- 1" thick X Side decorative panels are available as both open frame and with a plywood center panel.
- The X Side overlay has numerous applications including: single panel wall and base end panel overlays, double panel upright refrigerator end panel overlays, and 2 and 3 panel side by side wainscot panel overlays.
- Stiles, top rail and diagonal cross members are 3" wide, bottom rail is 6" wide. All exterior framing can be modified in width, but diagonal cross members are fixed at 3" in width.

Offering And Availability

All Conestoga products are available in a wide variety of specifications to satisfy your custom needs. The information below indicates any exceptions or limitations pertaining to the designs above. For a detailed listing of a particular product specification, refer to the page indicated.

Species	
Material Pricing Guide	All designs – 1" Alder, Cherry, Hard Maple, Hickory, Knotty Pine, Paint Grade Hard Maple, Walnut and White Oak only.
Edge Profiles	
pg 7.1	All designs – all 1" profiles available.
Framing Beads	
pg 7.2	All designs – design specific, no options available.
Panel Raises	
pg 7.2	All designs – 1/4" veneered panel only.
Options	
pgs 7.3-7.15	All options available except panel grooves.
Mullions	
pgs 6.1-6.11	X Side Panel – frame only and mullions not available. X Side Open – mullions not available.
Appliance Panels	
pg 6.22	Apply over plywood.
Matching/Complementary Drawer Fronts	
pgs 4.58-4.59	1" slab drawer front recommended.

*Note: Material calculated on overall width and height.

Wire Grille Inserts

- An accent option for frame only and mullion doors, Conestoga's Wire Grille inserts are woven, not welded, and crimped to achieve specific patterns and designs. Wire Grille inserts feature an electroplated finish with a clear lacquer topcoat for durability.
- Diamond mesh patterns are size specific – no options.
- Available in three attractive finishes
- Can be purchased cut-to-size or in full sheets.
- Cut-to-size Wire Grille inserts will have pattern centered side to side, top to bottom.
- Wire Grille inserts will be packaged separate from door and must be inserted by the customer.
- Minimum size of all inserts is 6" x 6".
- Wire Grilles can be held in place with standard clear plastic retainer moulding or wood retainer moulding. If 1/8" glass is used in conjunction with Wire Grille insert use #52 moulding (requires trimming) or #907 moulding.
- Grilles will flex during shipping and handling, but can be gently pulled back to original dimensions.
- Lead-time for all Wire Grille inserts is 10 business days.
- Expedite program not available.
- Exterior edges of Wire Grille inserts are sharp. Caution should be used when opening package and handling grille inserts to avoid cuts and other injuries.

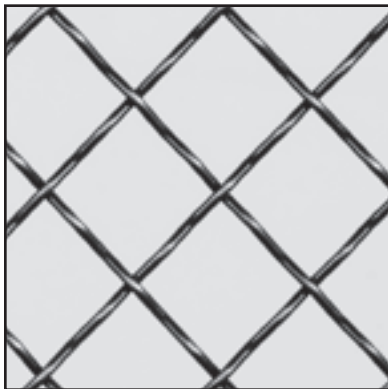

WG100 – Round Wire

- Double crimped, 1/16" round wire with 3/4" mesh openings.
- Cut-to-size Antique Brass, Oil-Rubbed Bronze, Satin Steel.
- 20" x 48" full sheet Antique Brass, Oil-Rubbed Bronze, Satin Steel.

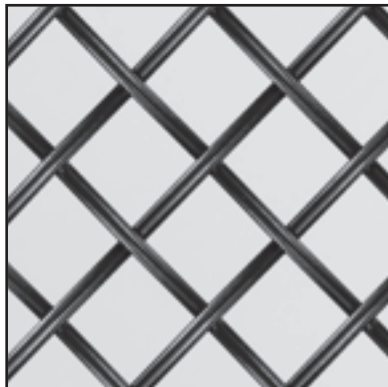

WG102 - Reeded Wire

- Single crimped, 1/16" x 1/8" reeded wire with 3/4" mesh openings.
- Cut-to-size Antique Brass, Oil-Rubbed Bronze, Satin Steel.
- 20" x 48" full sheet Antique Brass, Oil-Rubbed Bronze, Satin Steel.



Wire Grille Inserts (continued)

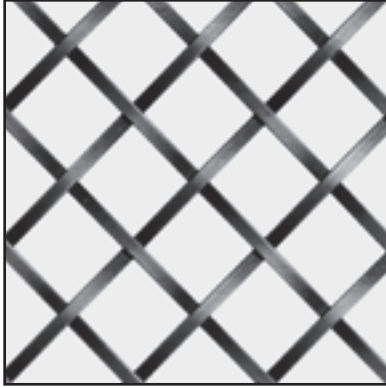

WG103 – Flat Wire

- Single crimped, 1/16" x 1/8" flat wire with 3/4" mesh openings.
- Cut-to-size Antique Brass, Oil-Rubbed Bronze, Satin Steel.
- 20" x 48" full sheet Antique Brass, Oil-Rubbed Bronze, Satin Steel.



WG104 – Reeded Wire

- Double crimped, 1/16" x 1/8" reeded wire with 1-1/4" mesh openings.
- Cut-to-size Antique Brass, Oil-Rubbed Bronze, Satin Steel.
- 20" x 48" full sheet Antique Brass, Oil-Rubbed Bronze, Satin Steel.



WG105 – Flat Wire

- Double crimped, 1/16" x 1/8" flat wire with 1-1/4" mesh openings.
- Cut-to-size Antique Brass, Oil-Rubbed Bronze, Satin Steel.
- 20" x 48" full sheet Antique Brass, Oil-Rubbed Bronze, Satin Steel.

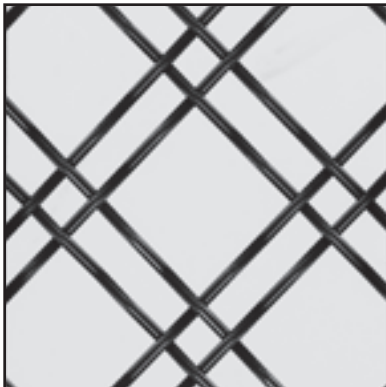

WG106 – Reeded Wire

- Double crimped, 1/16" x 1/8" reeded wire with a combination of 1/2" and 1-1/2" mesh openings.
- Cut-to-size Antique Brass, Oil-Rubbed Bronze, Satin Steel.
- 20" x 48" full sheet Antique Brass, Oil-Rubbed Bronze, Satin Steel.



Wire Grille Inserts (continued)

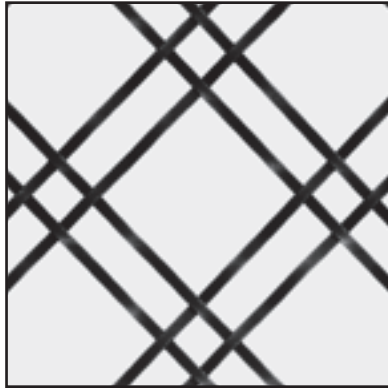

WG107 – Flat Wire

- Double crimped, 1/16" x 1/8" flat wire with a combination of 1/2" and 1-1/2" mesh openings.
- Cut-to-size Antique Brass, Oil-Rubbed Bronze, Satin Steel.
- 20" x 48" full sheet Antique Brass, Oil-Rubbed Bronze, Satin Steel.

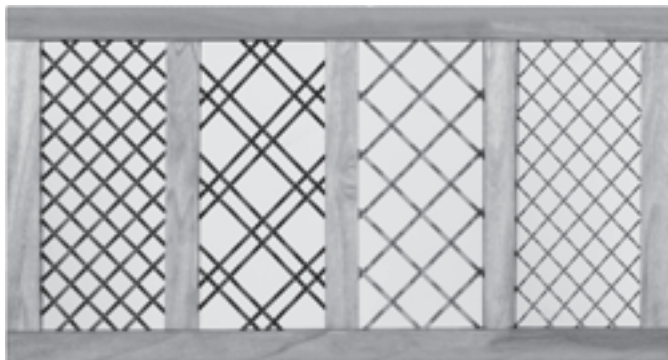

Wire Grille Display Unit

- Features 7 Wire Grille patterns and all 3 program finishes.
- Unit is dual sided 11" x 21".
- Maple framing is finished in a medium brown finish.
- Order using part #2601790A.
- Lead-time is 4 days.

Wainscot Panels

Wainscot panels can be ordered to match most door styles that Conestoga offers. Each wainscot panel is custom made to meet your exact size, panel and framing specifications.

Wainscot panels are typically constructed with multiple panels and/or wide bottom rails. A wainscot product is defined as any door or panel that exceeds 36" wide and 36" high, where the length or width exceeds 84", or that contains any framing (stile or rail) greater than or equal to 6" in width.

- When ordering wainscot products, specify all rail and stiles widths, including center framing pieces. Framing width of the wainscot panel will match the standard framing width of the door design requested unless otherwise noted by customer.
- Dimensioned sketches are preferred with each order to ensure correct order entry.
- Wainscot panels over 119" in width or height, or wainscot products that require more than six panels will be processed by Special Designs; upcharges apply.
- Bamboo cannot be ordered over 95-3/4" in length due to material availability.
- Stiles or rails over 2-5/16" in width may utilize framing material containing one or more glue joints. Number of glue joints is dependent on the overall width and length of the framing in question. See page 7.10 for framing width glue joint guidelines.
- Finished wainscot panels will have the face and exterior edges fully finished and topcoated. The back of the panel will receive only a clear coat of sealer or primer unless "Finished Back" option is requested. See the Finish Program section for pricing of Finished Back option.

Pricing

- Wainscot panel pricing is calculated using the door Design Charge multiplied by the number of panels specified, then added together with the Material Charge and any wide framing charges.
- If a wainscot panel exceeds 50" in width and 50" in height, an upcharge will be incurred due to the manual sanding process and special handling.
- Wainscot panels with stiles 8-13/16" to 15" will automatically receive a mullion type spline as structural reinforcement. The spline charge is per stile.
- Wainscot panels will receive an additional charge for oversize packaging if the panel exceeds 36" in width and 36" in height, or if any dimension exceeds 84".

Appliance Panels

Appliance panel selection must be noted when ordering. Conestoga offers appliance panels in the Apply Over Plywood construction method. Appliance panels are used on the main surface area of the appliance. For example, the door of a dishwasher would receive an appliance panel.

Apply over plywood appliance panels will have the following margins unless otherwise specified:

- Refrigerator panel – 1/2" margin on all sides.
- Other appliance panels – 1-1/2" bottom margin and 1/2" on all other sides.
- If non-standard margins are desired, dimensioned drawings must be submitted.
- Conestoga uses a composite core plywood as a backer with solid wood appliance panels.
- When ordering appliance panels list overall size of panel and specify required reveal/margin. Refer to the appliance manufacturer's specifications for this information.
- If a different appliance panel construction method is desired contact Customer Service.

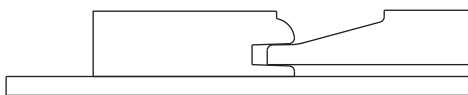

Apply over plywood wainscot panel pricing:

- 5 sq. ft. or under.
- Over 5 sq. ft.
- Multiple doors on one panel.



Edge Profiles

 B 3/4" only Rabbet: 7/16" deep 3/8" high	 B-2⁺ 3/4" and 1" Available w/MDF	 C 3/4" only Rabbet: 7/16" deep 3/8" high	 C-2⁺ 3/4" and 1" Available w/MDF	 CFP-2⁺ 3/4" and 1"
 E-2⁺ 3/4" and 1"	 FP 3/4" only	 H-2⁺ 3/4" and 1" Available w/MDF	 J-2⁺ 3/4" and 1"	 L-034* 3/4" and 1" Available w/MDF
 L-059⁺ 3/4" and 1" Available w/MDF	 L-120⁺ 3/4" and 1"	 L-149⁺ 3/4" and 1" Available w/MDF	 L-253 3/4" and 1" 5° back bevel Available w/MDF	 L-281⁺ 3/4" and 1"
 L-382⁺ 3/4" and 1" Available w/MDF	 L-686 3/4" and 1" 5° back bevel Available w/MDF	 L-772⁺ 3/4" and 1"	 L-803⁺ 3/4" and 1" Available w/MDF	 L-1160⁺ 3/4" and 1" Available w/MDF
 LC-2⁺ 3/4" and 1" Available w/MDF	 Machine Edge⁺ 3/4" and 1" Available w/MDF	 PRS-2⁺ 3/4" and 1" Available w/MDF	 RC-2⁺ 3/4" and 1"	 V-2⁺ 3/4" and 1" Available w/MDF

Premium Edge Profiles

additional charge per door.
 These three profiles require 2 additional working days.

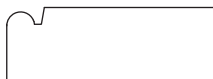

L-297*
3/4" and 1"



L-304
3/4" and 1"
5° back bevel



LC-Inset*
3/4" and 1"

* Drilling for concealed hinges is available on doors with these profiles.
 + FEP Option available.
 Images shown are not to scale.

FEP Rabbet Option







L-149 edge with FEP rabbet option

- Designed for use as a "finished end panel" to be used with Conestoga Cabinet Systems.
- All profiles marked with a + indicate FEP rabbet option is available.
- Available on 3/4" designs only.

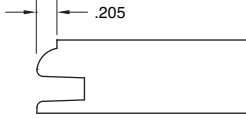
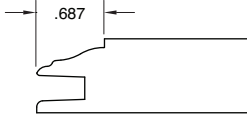
Not all framing beads and panel raises are available with all door designs – See Options and Availability pages.
 Design Charges include choice of published framing bead and panel raise.

Framing Beads

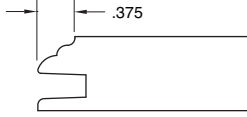
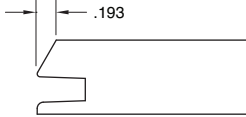
 Regular 3/4" and 1"	 Elite 3/4" only	 Ogee 3/4" and 1"	 Square 3/4" and 1"
 F-007 3/4" only	 F-877 3/4" only	 F-1223 3/4" only	

Panel Raises (dimensions shown are for 3/4" thick products only)

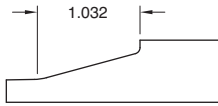
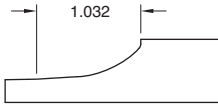
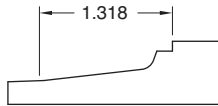
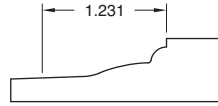
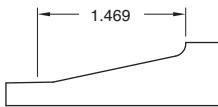
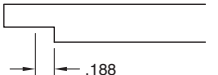
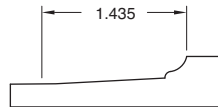
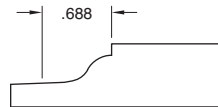
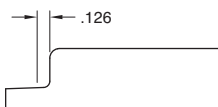
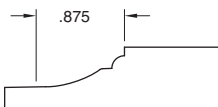
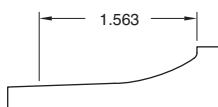
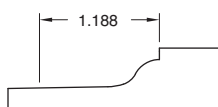
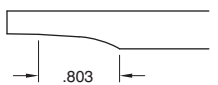
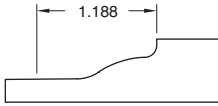
 Slant 3/4" and 1"	 G-Cove 3/4" and 1"	 Louis XIII 3/4" only	 M-Bead 3/4" and 1"
 P-008 3/4" and 1"	 P-057 3/4" and 1"	 P-106 3/4" only	 P-125 3/4" only
 P-225* 3/4" only	 P-420 3/4" only	 P-602 3/4" only	 Presidential 3/4" only
 Reverse G-Cove 3/4" and 1"	 RM 3/4" and 1"		

*P-225 raise not available when Colourtones, primers or Prism Paints are ordered.

All published 3/4" and 1" raises are available in hybrid products. Hybrid products consist of MDF panel and solid wood framing. 3/4" thick doors measure 5/8" finished panel thickness except Reverse G-Cove and P-057 which measure 3/8" thick and P-106 which measures 1/2" thick.

1" thick doors measure 3/4" finished panel thickness except Reverse G-Cove and P-057 which measures 1/2" thick.

Images shown are not to scale.

Options

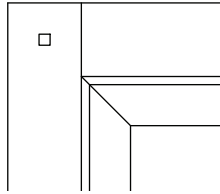

5/16" Square and Diamond Pegs

- For F-007, F-877, F-1223, Regular, Ogee and Square framing beads, pegs will be centered on stile one half of the total width of the stile and one half of the total width of the rail.
- For Elite framing bead submit dimensioned sketch showing peg location.
- When ordering two pegs per corner, specify either diagonal square or diagonal diamond pegs.
- Pegs will be sanded flush with face of framing.
- Available in all published species; peg specie must be specified.
- Multi-panel doors will be drilled for one peg at each interior joint, if requested.

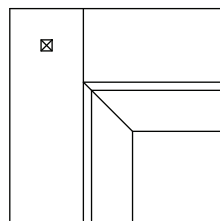
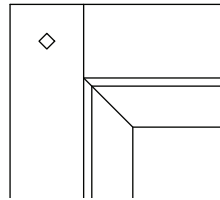

5/16" Pyramid Pegs

- Pyramid pegs will ship loose and doors will be pre-drilled to accept pegs.
- Pegs will be centered on stiles one half of the total width of the stile and one half of the total width of the rail.
- For Elite framing bead submit dimensioned sketch showing peg location.
- When ordering two pegs per corner, order as diagonal pyramid pegs.
- Multi-panel doors will be pre-drilled for one peg at each interior joint if requested.
- Available in all published species; peg specie must be specified.

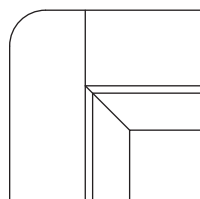
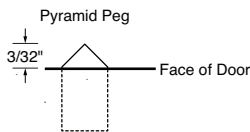

Radius Corners

- Specify 1/8", 1/4", 1/2" or 1" radius.
- Available with B-2, C-2, CFP-2, H-2, L-059, L-149, L-281, L-772, L-1160, LC-2, Machine Edge, PRS-2 and V-2 edge profiles only.

Options (continued)

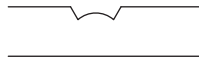
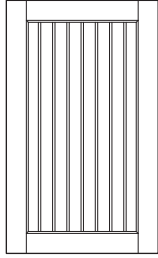

Groove width: 1/4"
 Groove depth: 1/16"

G-012 Panel Groove

- 1-1/2" spacing from center of groove to center of groove standard. Groove pattern begins from center of panel.
- Custom spacing available upon request.

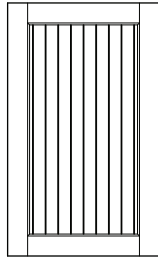

Groove width: 3/32"
 Groove depth: 3/64"

G-015 Panel Groove

- 1-1/2" spacing from center of groove to center of groove standard. Groove pattern begins from center of panel.
- Custom spacing available upon request.

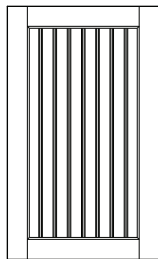

Groove width: 3/8"
 Groove depth: 1/8"

G-056 Panel Groove

- 1-1/2" spacing from center of groove to center of groove standard. Groove pattern begins from center of panel.
- Custom spacing available upon request.

Options (continued)

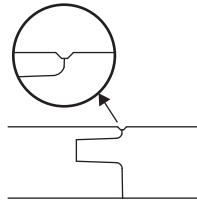
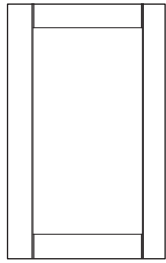

Essex Rout

- Rout is machined on full length of stiles.
- Rout is approximately 3/32" wide x 1/32" deep.
- Cannot be used with applied moulding designs, CRP-1389MT, CRP-10141, CRP-10605MT, CRP-10751MT, Fairhaven, Madison, miter designs or Presidential series.
- Add 1 day to lead-time.

Hybrid Panel Prep & Seal Option

- Hybrid doors and drawer fronts consist of 5-Piece construction utilizing solid wood framing with MDF panels. The MDF panel eliminates stave to stave glue lines that are sometimes visible after painting solid wood panels, as well as veneer seams and splits in plywood panel products.
- The Hybrid Panel Prep & Seal Option eliminates the problematic step of sealing machined areas of MDF panels in an assembled door. This option is especially recommended for products utilizing raised panels.
- This Prep & Seal Option consists of the application of a sealant on the machined areas of the panel. After curing, the sealant is scuff sanded to provide a smooth, finish ready surface. Normal prep sanding of the solid wood framing is still necessary.
- The Hybrid Panel Prep & Seal Option is valid only with unfinished doors and drawer fronts.

MDF 1-Piece, 5-Piece and Hybrid Seal Coat Option

- 1-Piece MDF.
- 5-Piece MDF and 5-Piece Hybrid.
- The Hybrid and MDF Seal Coat Option consists of an initial machine sanding step in the manufacturing process, followed by the application of a sealant on the face and all machined surfaces including the panel raise, framing bead and edge profile. No sealant is applied to the back and there is no further sanding after the seal coat is applied to the face. Must be scuff sanded by customer before primer is applied.
- Solid wood framing in Hybrid products may show wood characteristics such as pin knots, sap pockets on Cherry and mineral streaks.
- Testing for compatibility and adhesion between Conestoga's Seal Coat and customer's finish materials should take place on a sample door prior to finishing any large items or multi-piece projects. We recommend only **acid cured conversion varnish topcoats**. Conestoga assumes no responsibility for incorrect application of finish materials by the customer that may result in poor adhesion, color mismatch or other finish related issues. Conestoga will not warrant products due to incompatibility issues between our seal coat and non-DuraGuard finish materials.
- All 1-Piece MDF, 5-Piece MDF and 5-Piece Hybrid doors and drawer fronts are available to receive this option.
- This option is available on Hybrid and MDF unfinished products only.
- Add 1 day to lead-time.

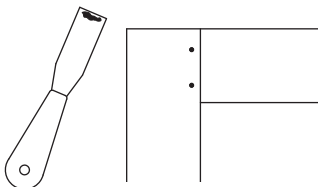

Putty Pin Holes



Options (continued)

End Grain Sealant Option

- Multi-panel products will incur a charge per panel.
 - Sealant is applied to the end grain of the panel raise and framing which results in a more uniform appearance between the end grain and face grain after finish is applied. While the End Grain Sealant Option will greatly improve the end grain appearance, end grain will still appear somewhat darker than non-end grain areas.
 - The End Grain Sealant Option is available on all published species, panel raises and edge profiles.
 - The End Grain Sealant Option is available with wiping and spray stains with the exception of Bordeaux, Dark Roast, Espresso, Nickel and Nitefall. End Grain Sealant Option is not available with primers, Colourtones or Prism Paints.
 - Add 1 day to lead-time.
-

Wood Conditioner Option

- Sanding methods used to sand the face of contoured miter framing differs from how center panels are sanded. Depending on specie and finish combinations chosen, stains sometimes absorb quite differently between components resulting in a picture frame effect.
- To minimize color contrast between framing and panels, Conestoga developed a process to apply a wood conditioning treatment to the face of contoured miter framing, crown and trim mouldings. The result is a more uniform finished appearance of all components.
- Available on unfinished and finished miter doors and drawer fronts that meet both the design and specie criteria listed below.
- List pricing for the Wood Conditioner Option:
 - ◆ Doors and wainscot panels.
 - ◆ Drawer Fronts.
 - ◆ Mouldings: Wood Conditioner is automatically added to moulding finish pricing for applicable specie/finish combinations.
- Any door design with a flat surface on the framing face (regardless of construction type) is not eligible for the Wood Conditioner Option because the wide belt sanding process negates the effect of the conditioner.
- Eligible published miter designs: CRP-10191, CRP-10318, CRP-10334, CRP-10875, CRP-10946, CRP-1420, LaSalle, Prestige, Rothsford, TW-10875, Wellston and Woodridge.
- The Wood Conditioner Option is limited to select Alder, Cherry, Hard Maple, Soft Maple and White Birch mitered designs.
- Eligible finishes include Autumn, Chestnut, Colonial, Cordovan, Driftwood, Ginger, Harvest Gold, Honey, Portabella, Saddle and Washington Cherry wiping stains.
- Available on unfinished miter designs and species listed above. Wood Conditioner Option must be selected.
- All prefinished miter door and drawer front designs that meet the design, specie and finish criteria will automatically receive Wood Conditioner on framing. Customers have the option to decline this service, but must notify Customer Service via phone, email or through Con-Nex, our online ordering program.
- All prefinished mouldings that meet the specie and finish criteria will automatically receive Wood Conditioner.
- The Wood Conditioner Option does not include sealing center panel end grain. To further enhance the appearance of panel end grain, select the End Grain Sealant Option.

Options (continued)



Weathered Grain Option

- The Weathered Grain Option consists of random removal of surface material from panels, framing and edge profiles. Softer portions of the wood's surface are removed from the product's face, resulting in a highly textured look and feel.
 - On 5-piece products such as the CRP-10 door, only the face of the panel and framing and the outside edges of the door will receive the weathering process. Recessed machined areas such as panel grooves and framing beads will not be weathered.
- Only a limited portion of our product offering including door designs, profiles and species are eligible to receive the Weathered Grain Option. This offering was arrived at by running a series of tests on a wide variety of products and product options.
 - ◆ Eligible 3/4" door designs: Albany, Amesbury, Ardmore, Bristol, Cortland, Crossbuck, CRP-10, CRP-10 Pilaster, CRP-10102, CRP-20, CRP-30, Flush Batten, Lafayette, Prestwick, Radcliffe, Sheldon, Slab, Stockbridge, TW-10, TW-10 Pilaster, TW-1038, TW-10716, TW-10916 and Yardley. Select 1" thick designs and profiles available – contact Customer Service.
 - ◆ Eligible 3/4" species: Alder, Bamboo, Cherry, Hickory, Knotty Pine, Quarter Sawn White Oak, Red Oak, Rustic Knotty Alder, Rustic Knotty Cherry, Rustic Knotty Hickory, Rustic Knotty Red Oak, Thermally Treated Poplar, Walnut and White Oak. All species listed also available in 1", except Bamboo and Thermally Treated Poplar.
 - ◆ Eligible framing beads: F-1223, Regular and Square only. Framing beads will not receive the weathering feature.
 - ◆ Eligible panel raises: P-057, Reverse G-Cove, and plywood center panels.
 - ◆ Eligible edge profiles: L-034, L-149, L-1160 and Machine Edge – edge profiles receive the Weathered Grain Option.
 - ◆ Eligible options with Weather Grain: back routed hand pull, concealed hinge boring, cross grain sand (back only), cut down framing, distressing levels 1 and 2, à la carte distressing options except wormhole clusters, G-012, G-015, G-056 panel grooves, putty pin holes, Soss hinge boring and wear sanding.
 - ◆ Eligible finishes: all Colourtones, Prism Paints, Truetones and wiping stains, both with and without glazes are available. Finish options include Antiquing and Heirloom treatments. All finishes default to a 5° sheen topcoat, 15° sheen topcoat is also available upon request.

Note: the Weathered Grain Option increases fiber raise which results in minor sand through in random areas. This is not considered defective and may actually enhance the weathered appearance.
 - Maximum panel width is 26".
 - Complementary products: non-beaded front frames, raised panel valances, slab fillers, fluted fillers, mouldings, S4S cabinet framing, B09 Beaded Panel, #13 Batten, #14 Scribe, #381 Baseboard, #538 Shaker Crown, #1126 Shaker Crown, #1529 Reverse Shaker Crown, #1809 Scribe, #2073 Refacer's Moulding, #2316 Scribe and #2317 Scribe.



Options (continued)

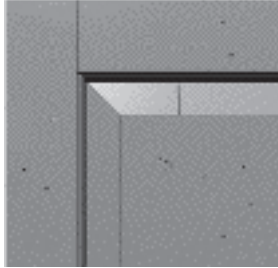

Rendering represents example only. Distressing is a random treatment; appearance of distressing will vary from piece to piece. A physical sample should be purchased before placing an order.

Distressing

- Level 1 – a random distribution of nicks and impressions.
- Level 2 – a random distribution of nicks and impressions, simulated wormholes, razor cuts and cut joints.
- Level 3 – a random distribution of nicks and impressions, simulated wormholes, rasp marks and cracks.
- Front frames, mouldings, ornaments and range hoods will receive modified distressing. Treatments on range hoods will be limited in intensity and will vary by style of hood.
- Not eligible on 1-Piece MDF, 5-Piece MDF or Hybrid products.
- Add 1 day to lead-time.

Distressing À La Carte

- Any of four distressing treatments can be ordered individually, or grouped in various combinations.
- Distressing treatments create a look of aged cabinetry that has withstood years of everyday use. Each treatment option will be applied in a random fashion to simulate varying degrees of wear.
- Not eligible on 1-Piece MDF, 5-Piece MDF or Hybrid products.
- Distressing treatment selections can be tailored to include one, two, three or four selections from the following options:
 - ♦ **Nicks and Impressions** – a number of indentations and nicks will be randomly applied across the face of the door or drawer front. Indentations of various shapes and sizes will be found on framing and panel.
 - ♦ **Rasp Marks** – located on the exterior edges of doors and drawer fronts, rasp marks are created by applying downward pressure on a large-tooth file which is dragged at an angle across the edge of the door's exterior profile.
 - ♦ **Razor Cuts & Cut Joints** – will give the appearance of splits or surface cracks radiating from the ends of framing or panel and will run parallel to the grain. Random cuts typically range from 2-1/2" to 5" in length and may vary in width. Cut joints consist of highlighting or widening random joints with a utility knife to create a look of joints that have slightly opened from years of stress and frequent use.
 - ♦ **Wormhole Clusters** – appearance of wormhole clusters will be spaced randomly on the face of the door or drawer front. Clusters will vary in size, shape and appearance.
- Pricing is based on a Design Charge plus a material square footage charge. The first option will incur a Design Charge, regardless of the treatment chosen. Each subsequent treatment will incur an additional Design Charge. The Material Charge will remain per square foot, regardless of the number of treatments selected.

Pricing example: Wormhole Clusters and Rasp Marks on a 15" x 25" door.
 Wormhole Clusters + Rasp Marks + Material Charge = list.

Options (continued)

Cross Grain Sanding

- The Cross Grain Sanding Option is available only on unfinished doors and drawer fronts.
 - Please note, even with cross grain removal, doors are not finish-room ready. To prepare properly for finishing, we recommend a light white wood sand.
 - This option is automatically included at no charge on prefinished products.
-

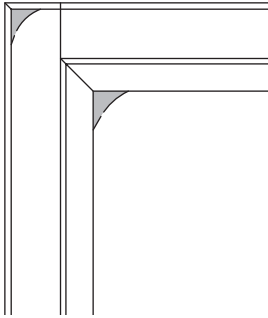

Wear Sanding

- The Wear Sanding Option provides an aged appearance to unfinished doors and drawer fronts. On raised panel designs, sanding is applied to the corners of the panel and the outside corners of the framing. Recessed panels, mullions and frame only designs will receive sanding on the outside corners of the frame. Sanding will be random and each corner will vary in appearance.
 - Wear Sanding is available on range hoods, but will be limited in intensity depending on the style of hood selected.
 - Wear Sanding is not available on front frames.
-

Antiquing

- Antiquing is a random post-finish sanding treatment that exposes raw wood corners and edges. This treatment provides a complementary worn look to our distressing packages.
- To achieve a heavier level antiquing, combine this option with the Wear Sanding Option.
- Antiquing is not available on front frames.
- Antiquing is available on range hoods, but will be limited in intensity and will vary by style of hood.

Options (continued)

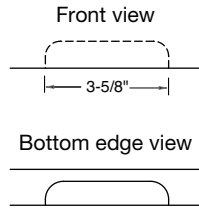
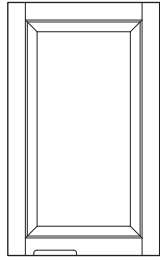

Back Routed Hand Pull

- Specify location: top or bottom and left, right or centered.
- Rout is 3-5/8" wide and 3/8" deep. When specifying left or right hand, pull will start 3" in from edge of door. Hand pull is centered on doors less than 10" wide.
- Available with the following published edge profiles: L-034, L-059, L-149, L-281, L-382, L-803, L-1160, LC-2, Machine Edge and V-2.
- Add 1 day to lead-time.

Non-Standard Width Framing

Non-Standard Width Framing (1-1/4" minimum size) Only available on mortise and tenon constructed doors

Width	
1-1/4" to std. width	
Std. width to 6-7/16"	
6-1/2" to 8-3/4"	
*8-13/16" and wider	

*Stiles 8-13/16" wide and over automatically receive a mullion-type spline as a structural reinforcement.

Miter Bead Design with Non-Standard Framing Widths GRP-10605MT, CRP-10751MT, CRP-1389MT, Madison, Presidential & SavannahMT

Framing Width	
Std. width to 6-7/16"	
6-1/2" to 8-3/4"	
*8-13/16" and wider	

Add 4 days to lead-time.

Wide framing may contain one or more glue joints, depending on overall desired width. The chart below lists the number of glue joints allowed in the different framing widths. These glue joints are considered acceptable.

Framing Glue Joint Parameters

Framing Width	Number of Acceptable Glue Joints
2-3/8" to 4" width	1 glue joint is acceptable
4-1/16" to 6" width	2 glue joints are acceptable
Over 6" in width	2 or more glue joints are acceptable

Options (continued)

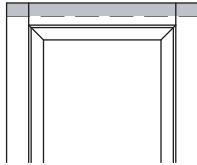

Cut Down (Width or Height)

- The Cut Down Option is available for Wood/MDF mortise and tenon doors and drawer fronts and 3-Piece and 5-Piece Intrigue, Strata and Vogue TTS Alternative Materials products that are manufactured to the minimum size and cut down to achieve a smaller size. This option is not available for mitered designs.

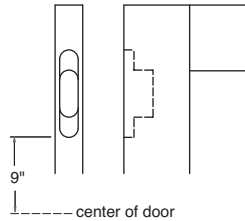
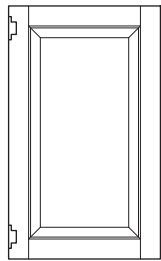

Soss Hinge Boring

- Assumes two bores.
- Routs are placed 9" off center, measured from the vertical center of the door to the start of the rout.
- Not available on doors over 42" high or under 25-1/8" high.

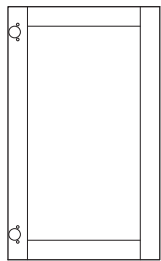

Concealed Hinge Boring: Pattern "A" 2.5mm

- Assumes two bores.
- Hole placement primarily designed for framed cabinetry.
- Boring consists of a 35mm diameter hole, 13.5mm deep with a 2.5mm tab dimension from the edge of the door.
- Insert holes are 8mm in diameter, 11.9mm deep, located 9.5mm from the center of the 35mm bore to the center of the 8mm insert bore.
- Specify with insert holes or cup only.
- Doors 8-13/16"– 42" long receive two bores.
- Doors 42-1/16"– 72" receive three bores (upcharge applies).
- Doors 72-1/16" and longer receive four bores with center holes set 25" in from each end (upcharge applies).
- Boring available on the following edge profiles only: B-2, CFP-2, H-2, L-034, L-059, L-149, L-281, L-297, L-382, L-803, L-1160, LC-2, LC-Inset, Machine Edge, PRS-2 and V-2.
- Concealed Hinge Boring is available on inset/prefit doors. Pattern "A" with or without insert holes, L-149, L-1160 and Machine Edge only.
- Pattern "A" accommodates the following hinge models for framed cabinetry:
 - Blum: Compact 33, 38C, 38N and 39C series.
 - Grass: TEC series.
 - Amerock: Matrix and 2811 series.
 - Mepla: ACC162 (screw-in version).
 - Salice: "S" series.
- Custom boring locations available. Specify dimension from top or bottom edge of door to center of cup locations.

With insert holes

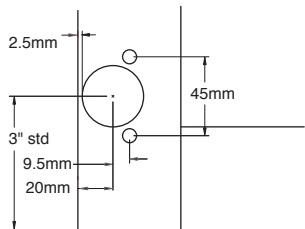

Cup Only

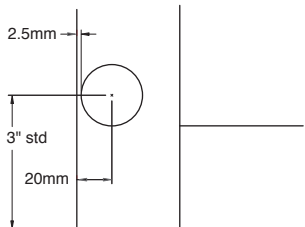

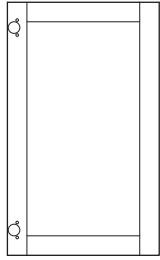

Options (continued)

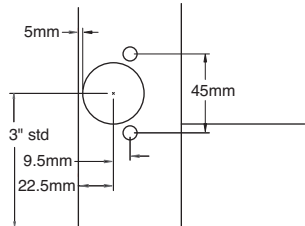
With insert holes

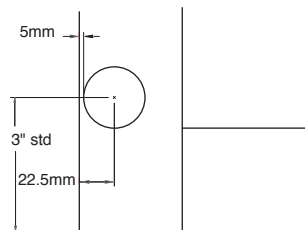

Cup Only

Concealed Hinge Boring: Pattern "B" 5mm

- Assumes two bores.
- Hole placement primarily designed for frameless cabinetry.
- Boring consists of a 35mm diameter hole, 13.5mm deep with a 5mm tab dimension from the edge of the door.
- Insert holes are 8mm in diameter, 11.9mm deep, located 9.5mm from the center of the 35mm bore to the center of the 8mm insert bore.
- Specify with insert holes or cup only.
- Doors 8-13/16"– 42" receive two bores.
- Doors 42-1/16"– 72" receive three bores with the third centered on the height of the door (upcharge applies).
- Doors 72-1/16" and greater receive four bores with center holes set 25" in from each end (upcharge applies).
- Boring available on the following edge profiles only: B-2, CFP-2, H-2, L-034, L-059, L-149, L-281, L-297, L-382, L-803, L-1160, LC-2, LC-Inset, Machine Edge, PRS-2 and V-2.
- Concealed Hinge Boring is available on inset/prefit doors with the following edge profiles: L-149, L-253, L-686, Machine Edge, L-947, L-967, L-304, L-996 and L-1160.
- Pattern "B" accommodates the following hinge models for frameless cabinetry:
 - Blum: 107, 120, 120+, 170, Diagonal 20, 30, 37, 45, Angle 25 and CLIP Top Series.
 - Grass: TEC, Nexis and Tiomos Series.
 - Salice: 200 Series (use 2mm mounting plate).
- Custom boring locations available - per door. Specify dimension from top or bottom edge of door to center of cup locations.

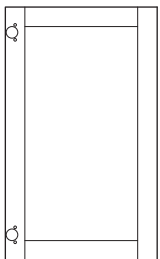
Concealed Hinge Boring: Pattern "C" 5mm

- Assumes two bores.
- Hole placement primarily designed for frameless cabinetry.
- Boring consists of a 35mm diameter hole, 13.5mm deep with a 5mm tab dimension from the edge of the door.
- Insert holes are 8mm in diameter, 11.9mm deep, located 9.5mm from the center of the 35mm bore to the center of the 8mm insert bore.
- Specify with insert holes or cup only.
- Doors 10"– 42" receive two bores.
- Doors 42-1/16"– 72" receive three bores with the third centered on the height of the door (upcharge applies).

Options (continued)

With insert holes

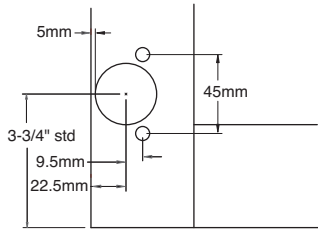

Cup Only

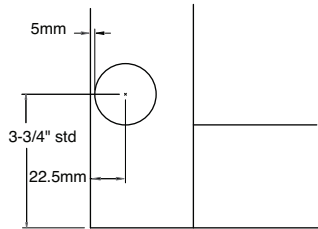

Concealed Hinge Boring: Pattern "C" 5mm (continued)

- Doors 72-1/16" and greater receive four bores with center holes set 25" in from each end (\$1.50 upcharge applies).
- Boring available on the following edge profiles only: B-2, CFP-2, H-2, L-034, L-059, L-149, L-281, L-297, L-382, L-803, L-1160, LC-2, LC-Inset, Machine Edge, PRS-2 and V-2.
- Concealed Hinge Boring is available on inset/prefit doors with the following edge profiles: L-034, L-149, L-253, L-686, Machine Edge, L-947, L-967, L-304, L-996 and L-1160.
- Pattern "C" accommodates the following hinge models for frameless cabinetry:
 - Blum: 107, 120, 120+, 170, Diagonal 20, 30, 37, 45, Angle 25 and CLIP Top Series.
 - Grass: TEC, Nexis and Tiomos Series.
 - Salice: 200 Series (use 2mm mounting plate).
- Custom boring locations available. Specify dimension from top or bottom edge of door to center of cup locations.

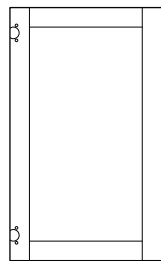

With insert holes

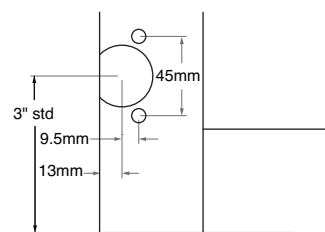

Cup Only

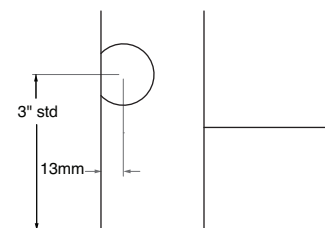

Concealed Bi-Fold Hinge Boring

- Hole placement is primarily designed for edge-mount style bi-fold hinges.
- Boring available on the following edge profiles only: B-2, CFP-2, H-2, L-034, L-059, L-149, L-281, L-297, L-382, L-803, L-1160, LC-2, LC-Inset, Machine Edge, PRS-2 and V-2.
- Boring consists of a 35mm diameter hole, 13.5mm deep, 12.5 mm on center from edge of the door.
- Insert holes are 8mm in diameter, 11.9mm deep, located 9.5mm from the center of the 8mm insert bore.
- Specify with insert holes or cup only.
- Doors 9-1/2" – 42" receive two bores.
- Doors 42-1/16" – 72" receive three bores with the third centered in the height of the door (upcharge applies).
- Concealed bi-fold rout accommodates Blum's CLIP top 60 degree bi-fold hinge (CWS #2103583).
- Custom boring locations available. Specify dimension from top or bottom edge to the center of cup locations.



Options (continued)

HK-XS Hinge Boring

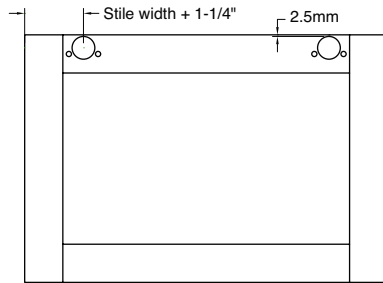

Pattern A

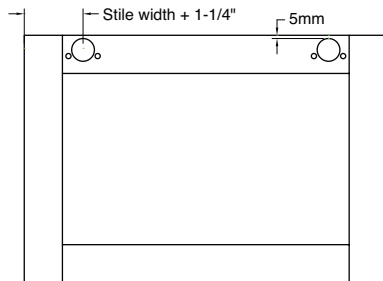

Pattern B

- Boring location designed specifically for Blum HK-XS lift mechanisms (CWS#'s 2103577, 2103578, 2103579 and 2103580).
 - ♦ Door width range: 12" – 72".
 - ♦ Door height range: 9-3/8" – 24".
- Hole placement is designed to rail mount concealed framed or frameless style hinges.
- HK-XS Pattern A Rout has a 2.5mm tab dimension from the edge of the door, primarily for framed cabinetry.
- HK-XS Pattern B Rout has a 5mm tab dimension from the edge of the door, primarily for frameless cabinetry.
- Boring consists of a 35mm hole 13.5mm deep placed on each end of the door 1-1/4" + the stile width of the door design.
- Specify with insert holes or cup only.
- Insert holes are 8mm in diameter, 11.9mm deep, located 9.5mm from the center of the 35mm cup bore.
- Doors 12" – 42" receive two bores.
- Doors 42-1/16" – 72" receive 3 bores (upcharge applies).
- Boring available on the following edge profiles: B-2, CFP-2, H-2, L-034, L-059, L-149, L-281, L-382, L-803, L-1160, LC-2, Machine Edge, PRS-2, V-2, L-297 and LC-Inset.
- Custom boring locations are not available.

Aluminum Hand Pull

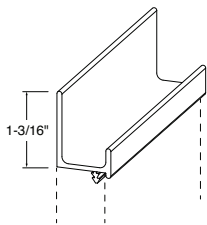
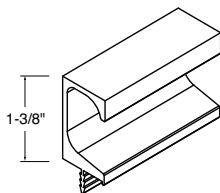
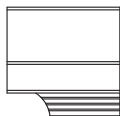
Front View
J-StyleSide View
C-Style

- Design Charge: per Slab door or drawer front, regardless of hand pull design selected.
- Material Charge:
 - J-Style – Natural Aluminum.
 - J-Style – Polished Chrome.
 - C-Style – Natural Aluminum.
- Widths: Min. doors – 2-3/4", drawer fronts – 6-3/8", Max. – 36".
- Available on all Intrigue, Strata and Vogue TTS Slab products, Synchronicity Super Matte Slab products and Mera and Vetro Synchronicity High Gloss Slab products.
- Not available with Sequential Grain Match Option.
- Doors and drawer fronts are routed on the top edge to accept hand pull – no options.
- Hand pulls are cut-to-size, labeled to match the corresponding panel, wrapped and shipped separately.
- Hand pulls are designed with an integrated inset spline. Silicone caulk or construction adhesive can be used to affix the hand pull to the panel.
- When ordering Slab doors or drawer fronts with the Aluminum Hand Pull Option specify the total height of the door, including hand pull. Conestoga will subtract the height of the hand pull and size the panel accordingly.
- When ordering Slab doors or drawer fronts with the hand pull option and concealed hinge boring, specify top or bottom for hand pull and left or right for hinge boring. For hinge bore to be located 3" from top edge, request 1-13/16" bore location on top/bottom of door.

Options (continued)



Wood/MDF Sample ID Label



Alternative Material Sample ID Label

Sample ID Label

- The Sample ID Label Option identifies specific attributes of door and drawer front samples. Labels are tack-free and easy to remove. It is intended to be replaced with your company's customized label.
- Available on doors and drawer fronts only; this option is not available on aluminum frame doors, specialty or accessory products.
- ID labels are available on unfinished and finished doors and drawer fronts.
- Sample ID labels utilize Conestoga nomenclature, customization is not available.
- Label content will vary depending on material selected.
- Wood/MDF label includes: Conestoga design, specie/grade, bead, raise, edge profile, selected options, finishing information and package date.
- Alternative Materials label includes: Conestoga Design, color, selected options, order number and package date.
- All finished doors or drawer fronts will receive a second disclaimer label along with an ID label.

Toe Kick Notch

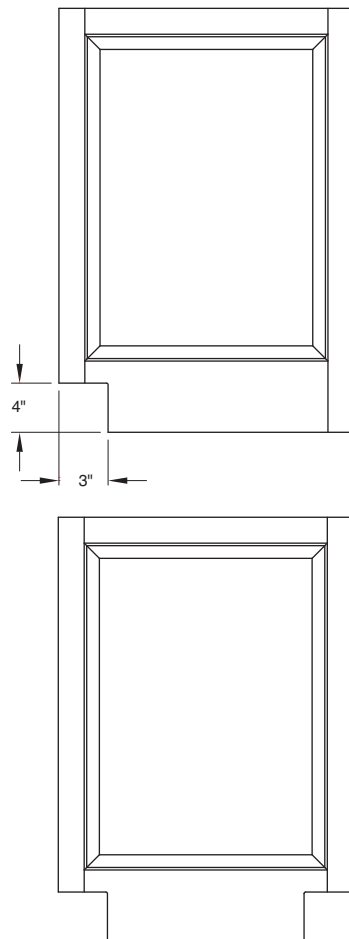

- Available in 3/4" thick 5-piece mortise and tenon doors with square bottom rails and Slab doors only.
- Standard Toe Kick Notch Option is 3" deep by 4" high and requires a bottom rail of 6" wide or greater. All other dimensions within the minimum and maximum depths and heights will be processed by Special Designs at no upcharge.
- Toe Kick Notch sizing is available in 1/16" increments.
- Minimum custom notch size is 2" deep by 2" high. Maximum custom notch size is 6" deep by 10" high.
- Width of bottom rail must exceed height of Toe Kick Notch by at least 2" to ensure joint integrity.
- Specify location of notch – left side, right side or with both left and right side notched.
- The inside corner of the Toe Kick Notch Option will have a 1/8" radius.
- Toe Kick Notch Option not valid with hinge boring.